

READ AND SAVE THESE INSTRUCTIONS



Thermal Coffeemaker

**USE AND CARE GUIDE FOR
MODEL ME10DTB**



IMPORTANT SAFEGUARDS

When using electrical appliances, basic safety precautions should always be followed, including the following:

- Read all instructions.
- Do not touch hot surfaces. Use handles or knobs.
- To protect against electric shock, do not place cord, plugs or appliance in water or other liquid.
- Close supervision is necessary when any appliance is used by or near children.
- Unplug from outlet when not in use and before cleaning. Allow to cool before putting on or taking off parts, and before cleaning the appliance.
- Do not operate any appliance with a damaged cord or plug or after the appliance malfunctions, or has been damaged in any manner. Contact Consumer Service for examination, repair or adjustment.
- The use of an accessory not evaluated for use with this appliance may cause injuries.
- Do not use outdoors.
- Do not let cord hang over edge of table or counter, or touch hot surfaces.
- Do not place on or near a hot gas or electric burner, or in a heated oven.
- To disconnect, press the ON/OFF/AUTO Button, (⏻) then remove plug from wall outlet.
- Do not use appliance for other than intended use.
- Be certain Lids are securely in place before operating appliance.
- Scalding may occur if the Lids are removed during the brewing cycles.

SAVE THESE INSTRUCTIONS

THIS PRODUCT IS FOR HOUSEHOLD USE ONLY.

ADDITIONAL IMPORTANT SAFEGUARDS

WARNING: This appliance generates heat and escaping steam during use. Proper precautions must be taken to prevent the risk of burns, fires, or other injury to persons or damage to property.

- All users of this appliance must read and understand this Use and Care Guide before operating or cleaning this appliance.
- The cord to this appliance should be plugged into a 120V AC electrical outlet only.
- Use **water only** in this appliance! Do not put any other liquids or food products in this appliance. Do not mix or add anything to the water placed in this appliance, except as instructed in the User Maintenance Instructions to clean the appliance.
- DO NOT attempt to move an appliance containing hot liquids. Allow appliance to cool completely before moving.
- Keep appliance at least 4 inches away from walls or other objects during operation. Do not place any objects on top of appliance while it is operating. Place the appliance on a surface that is resistant to heat.
- If this appliance begins to malfunction during use, immediately unplug the cord. Do not use or attempt to repair the malfunctioning appliance.
- If this appliance falls or accidentally becomes immersed in water or any other liquid, unplug it immediately. **Do not reach into the water! Do not use this appliance after it has fallen into or has become immersed in water.** Contact Consumer Service for examination and repair.
- Do not leave this appliance unattended during use.
- The appliance must be left to cool down sufficiently before adding more water to avoid splattering.
- Always use fresh, cool water in your appliance. Warm water or other liquids, except as listed in cleaning section, may cause damage to the appliance.
- DO NOT put Carafe into a microwave.
- DO NOT lift Hinged Water Reservoir Lid or the Filter Holder Lid until brewing is complete, and all parts have cooled.
- The Carafe is designed for use with this appliance. It must never be used on a range top.
- Do not use a damaged Carafe or a Carafe having a loose or weakened handle.
- **CAUTION:** To prevent injury when utilizing Pause and Pour (drip-stop) feature, replace Carafe within 1 minute of removing during brewing process.

POLARIZED PLUG: This appliance has a polarized plug, (one blade is wider than the other). To reduce the risk of electric shock, this plug is intended to fit into a polarized outlet only one way. If the plug does not fit fully in the outlet, reverse the plug. If it still does not fit, contact a qualified electrician. Do not attempt to modify the plug in any way.

SHORT CORD INSTRUCTIONS: A short power supply cord is provided to reduce the risk resulting from becoming entangled in or tripping over a longer cord.

Do not use an extension cord with this product.

ELECTRIC POWER: If the electric circuit is overloaded with other appliances, your appliance may not operate properly. It should be operated on a separate electrical circuit from other appliances.

WARNING: TO REDUCE THE RISK OF FIRE OR ELECTRIC SHOCK, DO NOT REMOVE THE BOTTOM COVER. NO USER-SERVICEABLE PARTS INSIDE. REPAIR SHOULD BE DONE BY AUTHORIZED SERVICE PERSONNEL ONLY.

CAUTION: To prevent Plasticizers from migrating from the finish of the countertop or tabletop or other furniture, place **NON-PLASTIC** coasters or placemats between the appliance and the finish of the countertop or tabletop.

Failure to do so may cause the finish to darken, permanent blemishes may occur or stains can appear.

Your product may vary slightly from illustration.

Parts Identification

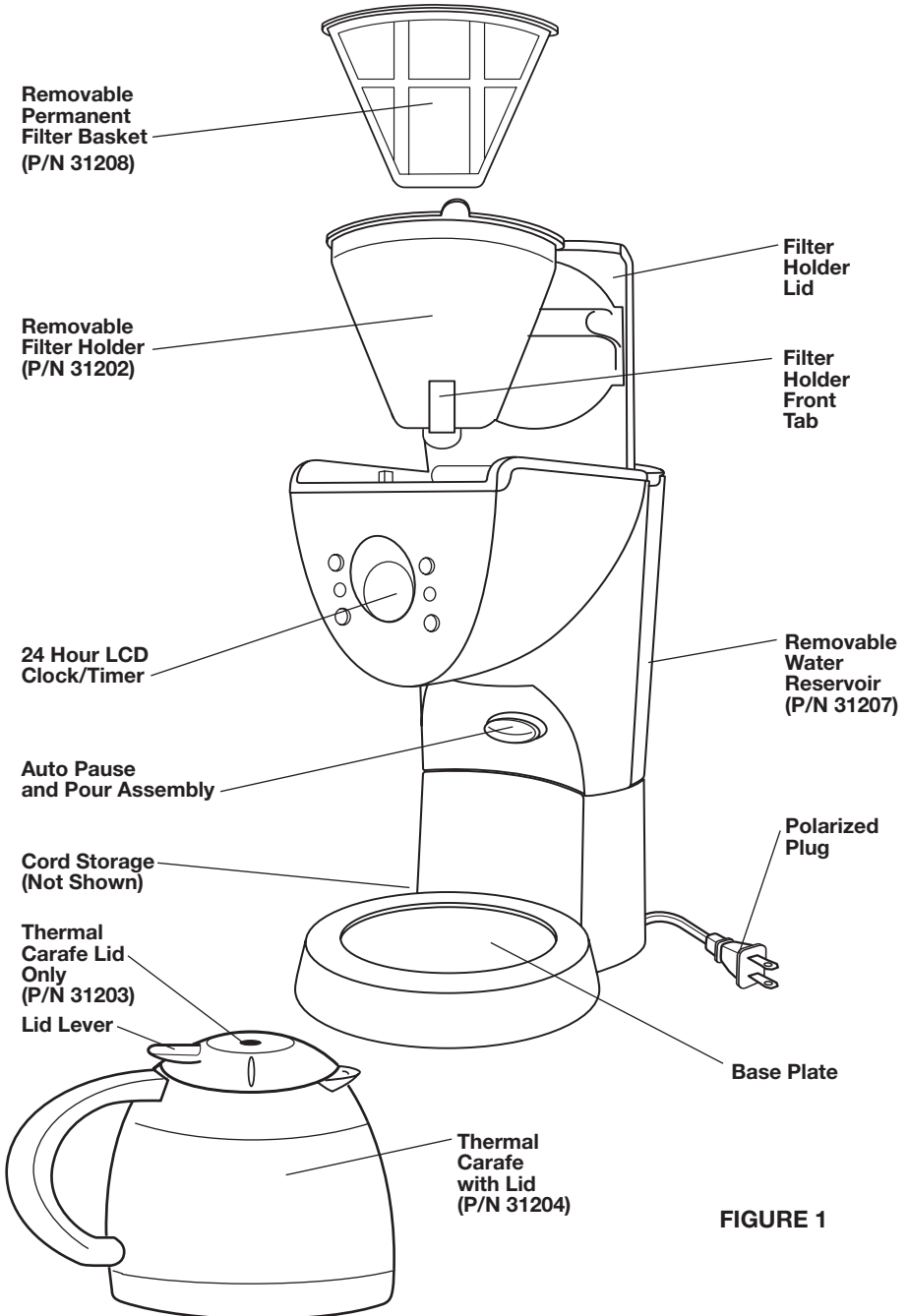

FIGURE 1

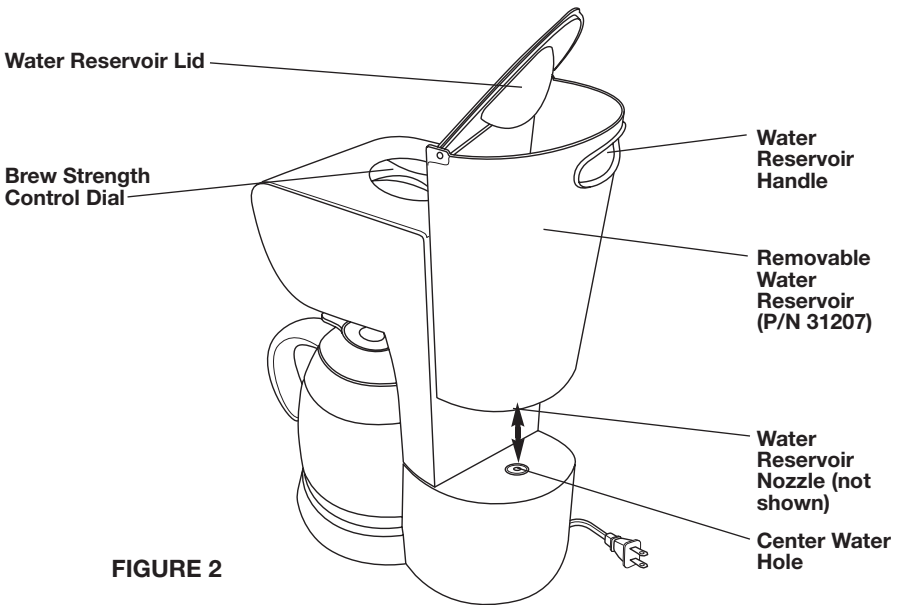



FIGURE 2

Control Panel

 **ON/OFF/AUTO Button.** Use this Button to turn the unit ON and to start the brewing process. Press the ON/OFF/AUTO Button to activate the AUTO Timer. Turn the unit OFF by pressing this Button when the brewing cycle is complete.

The blue BREW Light, below the ON/OFF/AUTO Button will illuminate when the Coffeemaker is brewing.

Hr Hour Button. Use this Button to advance the hour hand to the correct hour when setting the time.

Min Minute Button. Use this Button to advance the minute hand to the correct minute when setting the time.

 **SET TIMER Button.** Press this Button to program your Coffeemaker to start brewing at a specified time.

The amber SET TIMER Light, below the SET TIMER Button will flash as the Coffeemaker is being set; the Light will illuminate steadily to indicate AUTO Program has been activated.

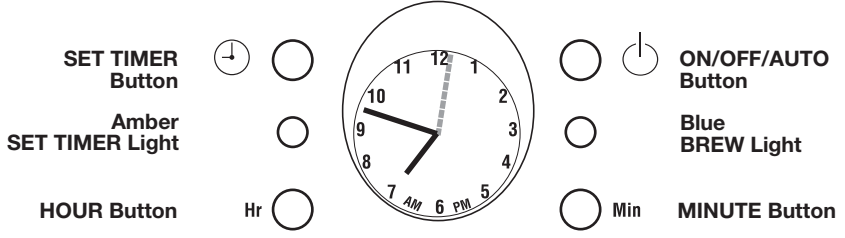

FIGURE 3

Before Using Your Programmable Coffeemaker

WARNING: To reduce risk of fire or electric shock, do not immerse cord, plug or appliance in water or any other liquid.

1. Before preparing coffee in your new Coffeemaker, thoroughly clean the Removable Water Reservoir, Thermal Carafe, Carafe Lid, Removable Filter Holder and Permanent Filter Basket in warm, soapy water. Rinse and dry thoroughly. Replace clean disassembled parts.

NOTE: Do not dry the inside of the Removable Water Reservoir with a cloth because this will leave a residue of lint and may clog your Coffeemaker.

2. To replace the Removable Filter Holder into the Coffeemaker's Cavity, rotate the front tab so that it faces the front right of the Coffeemaker. The Pause and Pour Lever, located on the bottom of the Filter Holder, sits down into the back of the Cavity; the single clip will be at the front of the unit. Press the Filter Holder down into place. The Lid will be fully closed when properly assembled.
3. Clean the inside of the Coffeemaker by brewing 2 full Carafes of clean, cool water (see Brewing Instructions). Do not place the Permanent Filter Basket or coffee in the Removable Filter Basket for this initial cleaning.

NOTE: At the end of the first brewing cycle, press the ON/OFF/AUTO Button to turn the Coffeemaker OFF and wait 10 minutes for the appliance to cool. Empty Carafe and replace onto Base Plate. Add fresh cool water to the Water Reservoir. Press the ON/OFF/AUTO Button twice to turn the Coffeemaker ON. The blue BREW Light will illuminate; brew a second Carafe. Discard water. Your Coffeemaker is now ready for use.

Permanent Filter Basket

Your Coffeemaker comes with a Permanent Filter Basket, eliminating the need for disposable paper filters. After daily use, the Removable Permanent Filter should be washed in hot, sudsy water. Rinse thoroughly.

Brewing Instructions

1. Place the Thermal Coffeemaker on a flat, level surface.
2. Open the Filter Holder Lid using the lip located on top of the Coffeemaker. (See Figure 1).
3. If the Removable Filter Holder is not already in position, replace following the instructions outlined in step 2 in the “Before Using Your Programmable Coffeemaker” section of this Use and Care Guide. Place the Permanent Filter Basket into the Filter Holder. The notched cutout of the Permanent Filter Basket will face the right side of the Holder as it slips into position. Fold the Handle down.
4. Add 1/2 to 1 tablespoon of drip or regular grind coffee for each cup of coffee desired into the Filter Basket.
5. You may choose to brew your coffee with a stronger BREW STRENGTH. To do so, turn the Brew Strength Control Dial located on the top of the unit. The arrows indicate a stronger or lighter brew strength. (See Figure 4.)

NOTE: Additionally, to further brew a stronger or milder coffee, adjust amount of coffee to suit your taste.

NOTE: We recommend using coffee ground specifically for automatic drip coffeemakers.



FIGURE 4

6. Close the Filter Holder Lid. Make sure it fits snugly and shuts fully against the Coffeemaker.
7. The Removable Water Reservoir is transparent so you can monitor the water level. Grasp the Handle on the back of the Water Reservoir and pull out and then up to remove it from the Base.
8. Add fresh, cool water to the Removable Water Reservoir. Close the Water Reservoir Lid and replace the Water Reservoir onto the Base. Fit the Water Reservoir's extended water nozzle over and down and into the large center

Brewing Instructions *(Continued)*

opening at the back of the Base. The Water Reservoir will snap into place as you press it firmly against the body of the machine. Make sure the Removable Water Reservoir is correctly positioned and in place before starting.

9. To replace the Carafe Lid, twist it until the Lid Lever is opposite the Spout and sits directly over the Handle of the Carafe. Make sure the Carafe Lid is properly secured onto the Carafe. Place the Carafe onto the Base.

IMPORTANT: Always use fresh, cool water in your appliance. Warm water or other liquids, except as listed in the Care and Cleaning Instructions, may cause damage to the appliance.



NOTE: The amount of brewed coffee will always be less than the amount of water placed into the Coffeemaker, since about 10% is absorbed by the coffee grounds and filter.

10. Locate the Cord Storage area at the bottom back of the unit. Extend cord, fitting it into the bottom cord notch, and plug the unit into a 120V, AC electrical outlet. The second hand and AM/PM display on the bottom of the blue-lit analog Clock will begin to flash. (See Figure 3.) Set the Clock following the instructions below.

Setting the Clock

1. When you plug the unit in, the second hand and AM/PM display will flash until the time of day is set.
2. To set the Clock, press the HR Button. Release the Button when the correct AM/PM is displayed and the hour hand is at the correct position. The second hand will begin sweeping across the face of the clock to keep the time. Press the MIN Button until the correct minutes are displayed.

Setting the AUTO Timer

1. Press the  SET TIMER Button. The amber SET TIMER Light will flash. Press the HR and MIN Buttons as described in “Setting the Clock” section above, until the AUTO Timer is set to the correct future brewing time.
2. Press the  ON/OFF/AUTO Button to activate the AUTO Timer. The Clock will revert back to show the time of day. The amber Light will glow steady to indicate the AUTO Timer is ON.

To Start Brewing Coffee Immediately

1. For optimal holding temperature, rinse the inside of Thermal Carafe with warm water before brewing; empty and make sure the Carafe Lid Lever is at the back of the Carafe and the Lid is properly secured. Place Carafe onto Base Plate, making sure it is firmly set against the silver Auto Pause and Pour Assembly of the Coffeemaker. (See Figure 1.)
2. Check to make sure the Removable Water Reservoir is filled; correctly positioned and in place before starting.
3. Press the ON/OFF/AUTO Button. The blue BREW Light will illuminate as the Coffeemaker begins brewing. Once the brewing cycle is complete, the Coffeemaker will turn itself OFF.

To Start Brewing Coffee at the Programmed Time

1. At the programmed time, the Coffeemaker will turn itself ON automatically. The blue BREW Light will illuminate as the Coffeemaker begins brewing. Coffee will begin flowing into the Thermal Carafe. Once the brewing cycle is complete, the Coffeemaker will turn itself OFF.

NOTE: The amount of coffee in the Carafe may be slightly less than the amount of water placed in the Water Reservoir, since some of the water is absorbed by the coffee grounds.

Auto Pause and Pour Feature

1. To pour a cup of coffee before the brew cycle is complete, simply remove the Carafe from the Base Plate and pour. Brewing will continue but dripping will automatically pause. Return the Carafe to the Base Plate within 1 minute; dripping will resume.

NOTE: The Thermal Carafe must be placed and centered onto the Base Plate, the Carafe should rest firmly against the silver Auto Pause and Pour Assembly of the Coffeemaker (see Figure 1) to allow proper operation of the Auto Pause and Pour Feature.

2. Remove the Thermal Carafe from the Base Plate. Always keep the Carafe Lid on the Carafe when pouring the coffee. Depress the Thumb Lever and pour.

CAUTION: To avoid injury when using the Auto Pause and Pour Feature while the Coffeemaker is still brewing, the Thermal Carafe with Lid must be replaced on the Base Plate, under the Filter Holder within 1 minute to prevent the Filter Basket from overflowing.

To Brew a Second Pot of Coffee

1. To brew a second pot of coffee, wait 10 minutes and allow the Coffeemaker to cool. Empty used coffee grounds and repeat steps for brewing coffee.

CAUTION: Failure to allow Coffeemaker to cool may cause water to overheat and spray hot steam. The hot steam can cause severe burns.

User Maintenance Instructions

This appliance requires little maintenance. It contains no user serviceable parts. Do not try to repair it yourself. Refer it to a qualified appliance repair technician if servicing is needed.

WARNING: Unplug from wall outlet before cleaning.

Care And Cleaning Instructions

1. Always make sure the Coffeemaker is OFF, the BREW Light is off, and the unit is completely cool before cleaning.
2. After daily use, the Removable Filter Basket, Carafe and Carafe Lid should be washed in warm, soapy water.
3. If necessary, wipe the outside of the Coffeemaker with a soft, damp cloth and wipe dry. Do not use abrasive cleansers, scouring pads or steel wool.

Storage Instructions

Unplug unit; store in its box or in a clean, dry place. Never store it while it is hot or still plugged in. Cord should be fed into the Cord Storage area. Never wrap cord tightly around the appliance. Do not put any stress on the cord where it enters the unit, as it could cause the cord to fray and break.

Descaling

We recommend that you descale your Coffeemaker once a month because mineral deposits can form a coating in the Coffeemaker, causing slower brewing time and possibly an off flavor in the coffee. Use a cleaner recommended for coffee-makers or the solution described below. To descale your unit:

1. Remove and fill the Water Reservoir using 1/4 white vinegar and 3/4 fresh, clean, cold water. Replace Water Reservoir following the instructions outlined in the “Brewing Instructions” section of this Use and Care Guide.
2. Place the clean Permanent Filter Basket into the Removable Filter Basket Holder, then close the Lid. Place empty Carafe on Base Plate.
3. Wait 2 hours before proceeding. This will allow the vinegar time to break down the lime and mineral deposits.
4. After 2 hours, following the “Brewing Instructions,” outlined, brew the vinegar/water descaling solution through the Coffeemaker and discard the brewed solution.

NOTE: While performing this procedure do not use a filter or coffee grounds.

5. Repeat the 10 cup brewing process at least 4 times with fresh, clean, cold water to ensure that the vinegar in the Water Chamber and Thermal Carafe has been flushed.

NOTE: An easy way to determine if all the vinegar has been rinsed out is to sprinkle a small amount of baking soda into the water in the Carafe after it has completed the brewing cycle. The baking soda will react with the vinegar. A gentle fizzing indicates that there is still vinegar in the water and the procedure should be repeated. If there is no reaction then it means that all of the vinegar has been rinsed clean.

LIMITED ONE-YEAR WARRANTY

Warranty Coverage: This product is warranted to be free from defects in materials or workmanship for a period of one (1) year from the original purchase date. This product warranty is extended only to the original consumer purchaser of the product and is not transferable. For a period of one (1) year from the date of original purchase of the product, our Repair Center will, at its option, either (1) repair the product or (2) replace the product with a reconditioned comparable model. These remedies are the purchaser's exclusive remedies under this warranty.

Warranty Service: To obtain warranty service, you must call our warranty service number at 1-800-233-9054 for return instructions on how to deliver the product, in either the original packaging or packaging affording an equal degree of protection to the Repair Center specified below. You must enclose a copy of your sales receipt or other proof of purchase to demonstrate eligibility for warranty coverage.

To return the appliance, ship to: **To contact us**, please write to, call, or email:

ATTN: Repair Center
708 South Missouri Street
Macon, MO 63552 USA

Consumer Relations Department
PO Box 7366
Columbia MO 65205-7366 USA
1-800-233-9054
E-mail:consumer_relations@toastmaster.com

What Is Not Covered: This warranty does not cover damage resulting from misuse, accident, commercial use, improper service or any other damage caused by anything other than defects in material or workmanship during ordinary consumer use. This warranty is invalid if the serial number has been altered or removed from the product. This warranty is valid only in the United States and Canada.

LIMITATION ON DAMAGES: THERE SHALL BE NO LIABILITY FOR ANY INCIDENTAL OR CONSEQUENTIAL DAMAGES FOR BREACH OF ANY EXPRESS OR IMPLIED WARRANTY OR CONDITION ON THIS PRODUCT.

DURATION OF IMPLIED WARRANTIES: EXCEPT TO THE EXTENT PROHIBITED BY APPLICABLE LAW, ALL IMPLIED WARRANTIES AND CONDITIONS, INCLUDING, WITHOUT LIMITATION, IMPLIED WARRANTIES AND CONDITIONS OF MERCHANTABILITY AND FITNESS FOR A PARTICULAR PURPOSE OR USE ON THIS PRODUCT ARE LIMITED IN DURATION TO THE DURATION OF THIS WARRANTY.

Some jurisdictions do not allow the exclusion or limitation of incidental or consequential damages, or allow limitations on how long an implied warranty lasts, so the above limitations or exclusions may not apply to you. This warranty gives you specific legal rights and you may have other rights under the laws of your jurisdiction.

For more information on our products, visit our website:
www.maxim-toastmaster.com.